



**UNO MINDA**

DRIVING THE NEW

# Seating presentation busworld – South Asia - Jakarta

*May- 2024*



# UNO Minda Limited – Seating Division

Formerly known as Harita Seating Systems Limited



# Company overview (UML –SD)

UML -SD provides a complete seating solutions for automotive applications

Product :           Seats for Buses, Tractors, CV's, 2W's & 3W's  
  
Foams & Interior modules for passenger cars  
  
Structural components for CVs and tractors

Facilities : 8 production plants & 1 R&D center

Certification : IATF 16949, ISO 14001 & OHSAS 18001

R&D :               100% In house test lab for AIS, ADR & ECE Certification;  
  
Registered with Department of Scientific & Industrial Research (DSIR)  
  
Test facility accredited by NABL as per ISO/IEC 17025:2005;  
  
Certified by CIRT, ICAT, GARC for Domestic and TUV, VCA for Europe

## Plants and its year of establishment

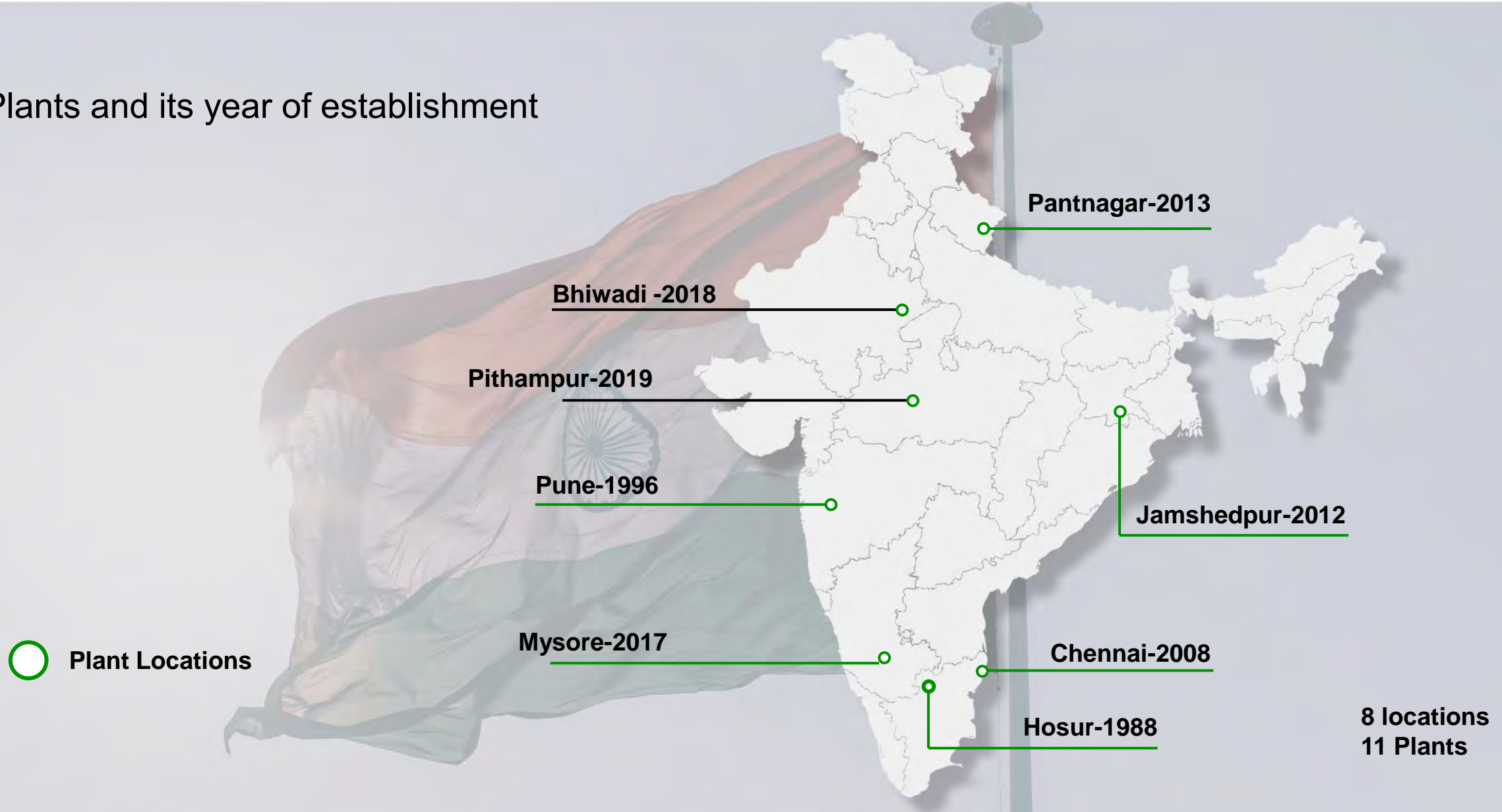

## Growing ASEAN Presence

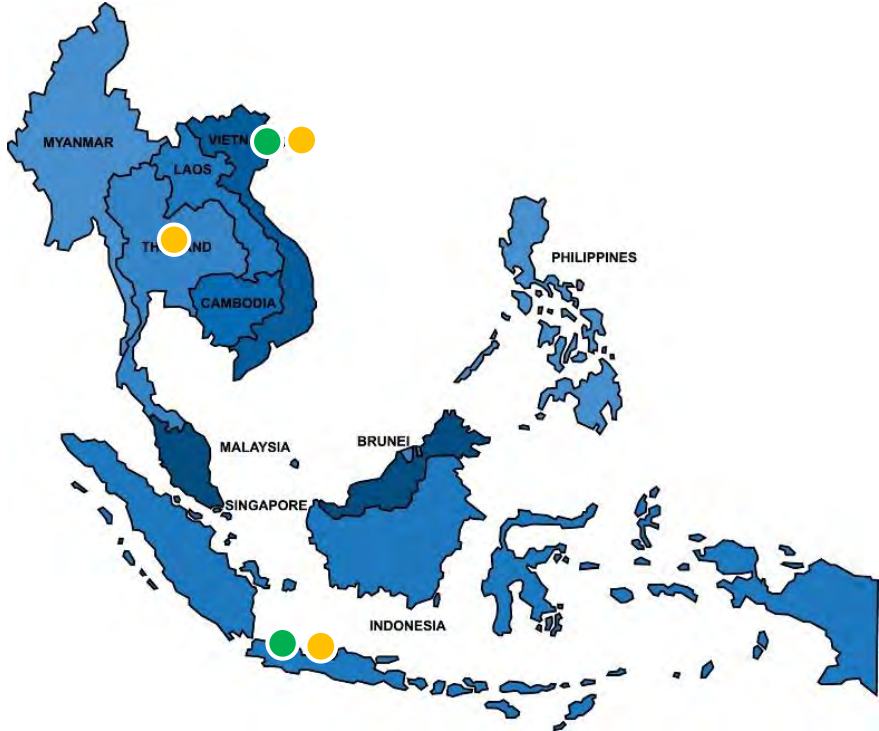









 **2** Plants

 **5** Sales Offices

 **1** Engineering Centers

● **Asia (w/o India)** (2) [1]

<b>Indonesia</b> (Karawang)	(1)  
<b>Taiwan</b> (Tainan)	[1] 
<b>Thailand</b> (Bangkok)	
<b>Vietnam</b> (Vin Phuc)	(1)  
<b>Japan</b> (Nagoya)	
<b>South Korea</b> (Pyeongtaek)	

# Exports locations

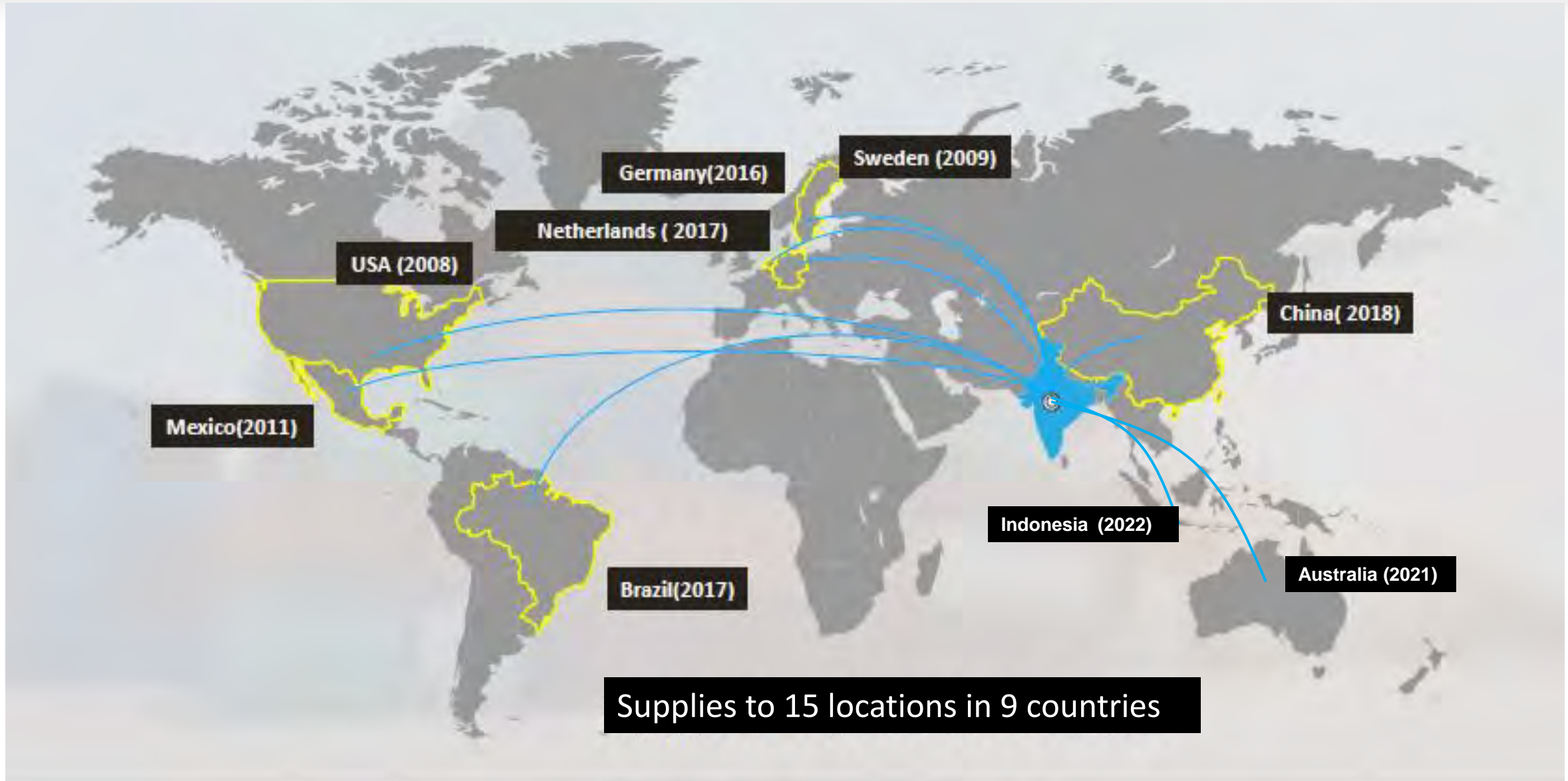

- Enhancing our footprint every year globally and challenging our self to be a global player in the segment

Complete design solution provider from concept to serial production with in-house capabilities of design, virtual validation, proto type, tool development, testing and homologation certification.

## Registered under



## Accredited by



## Certified by



## ➤ Design

- Catia V5-6 R22,
- Pro E Wildfire 10.
- Autocad R25

## ➤ CAE analysis

- Altair Hyper works V19

## ➤ Prototyping

- CNC Foam carving
- 3D Printing

## ➤ Testing facilities

- Road condition data acquisition
- Pressure mapping
- Multi axis simulation table

## ➤ Certification facilities:

- In house certification (AIS, ADR & ECE)

## ➤ Design, Proto & Testing engineers : 52

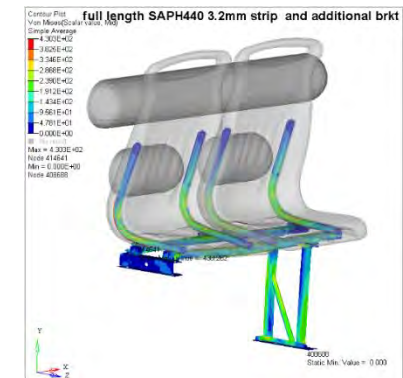
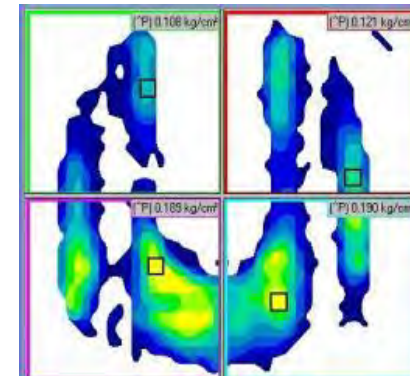
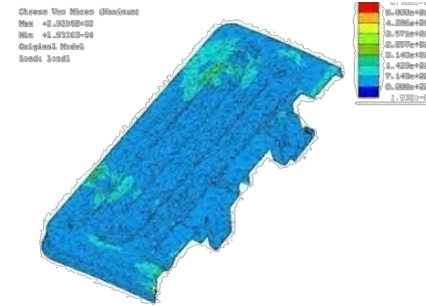
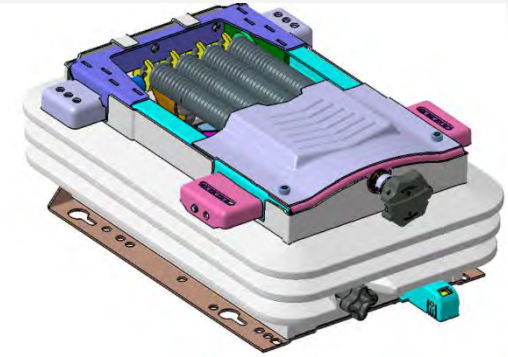
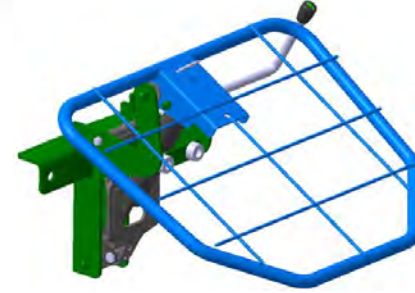



# R&D proto and testing capabilities

3-D Printing



Vibration Test Rig



Durability Testing Capabilities



CNC Foam Machining



Sub-System Testing Capabilities

➤ 100% In house test facilities for AIS / ECE / EU / ADR / ISO / IS certification testing.

# Product designs

Bus passenger seats



Commercial vehicle seats



Tractor, off-road & Lawn mover



2,3 Wheeler seats and accessories



Foams, armrest, headrest



Composites and NVH



## Seat strength test

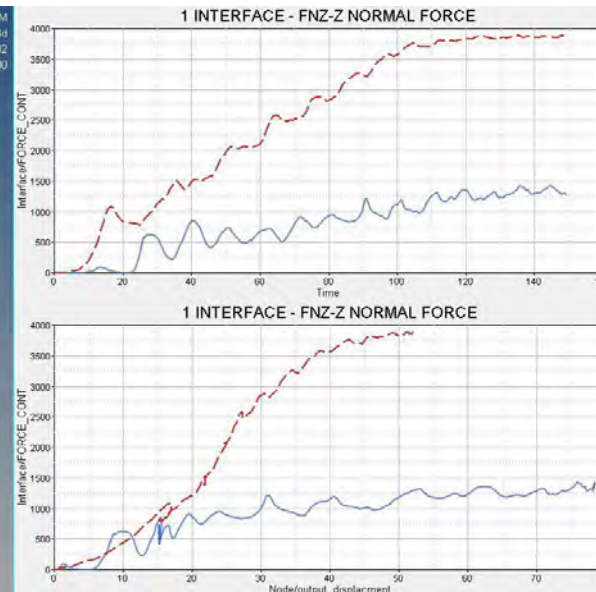
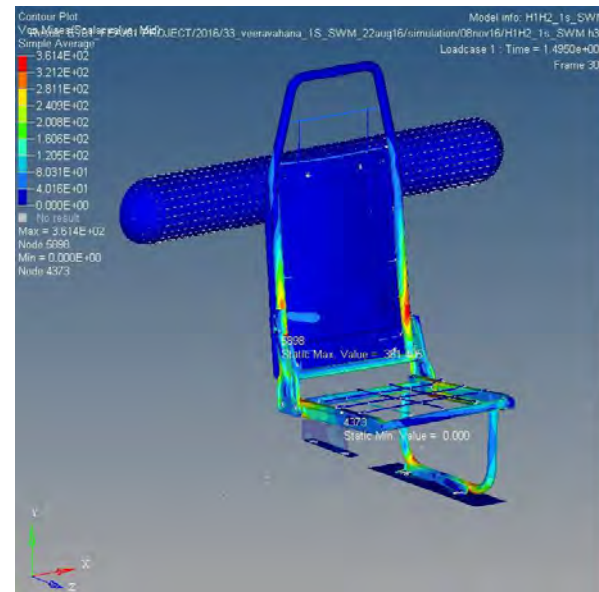
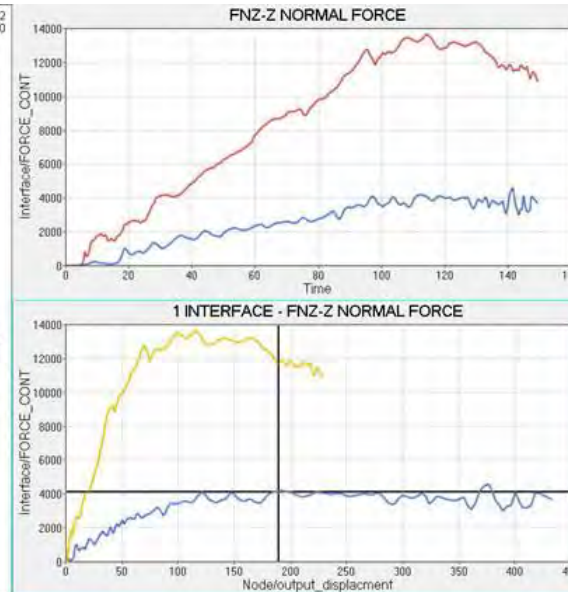
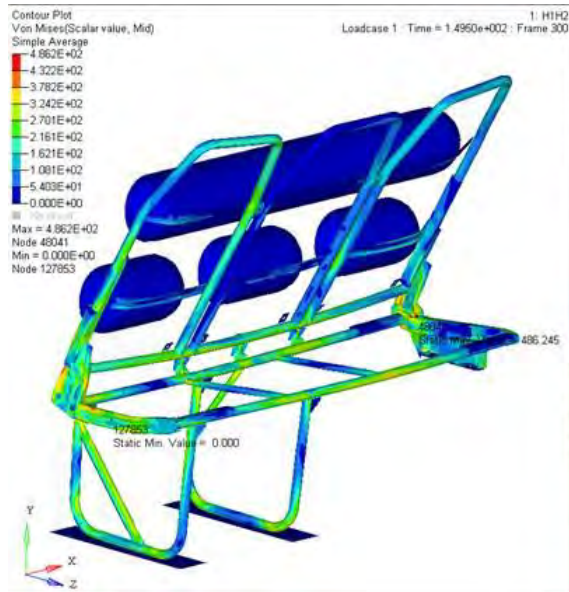
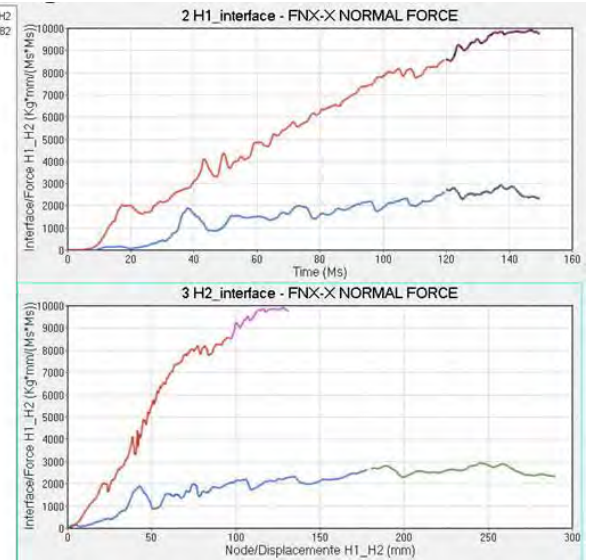
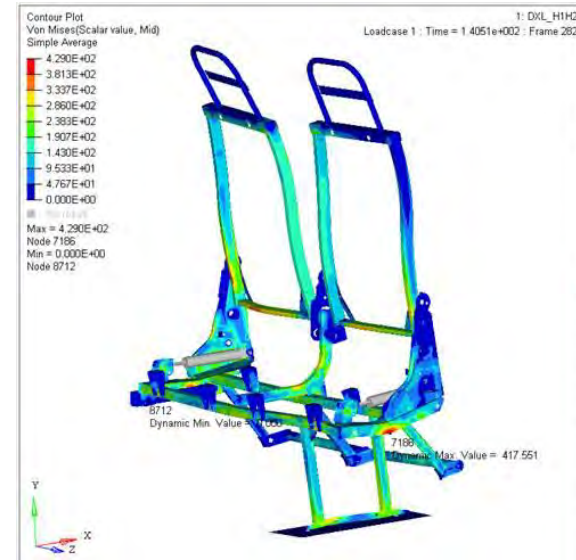
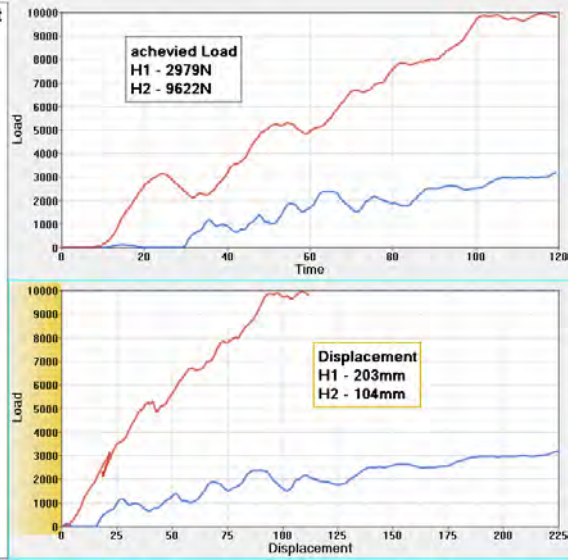
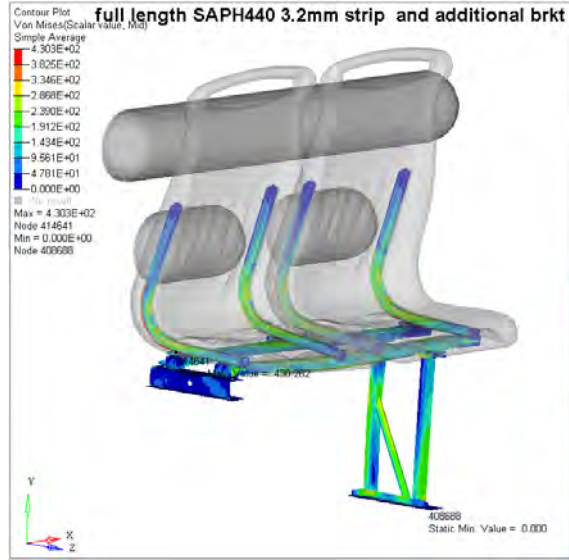

# Comfort evaluation – Pressure mapping



Backrest

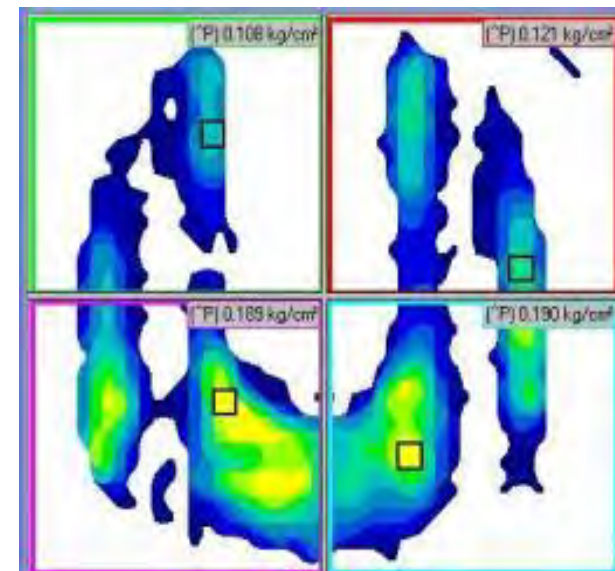

Seat base

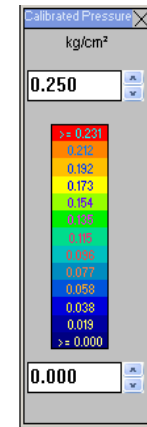

# Regulatory tests as per AIS 023

H-Point & Dimension measurement



Seat strength test - H1 H2 test



Energy Dissipation Performance



# Strength testing capabilities

Seat belt anchorage test



Bottle Holder pull off test



Calf support strength test



Grab handle pull off test



Sand bag drop test

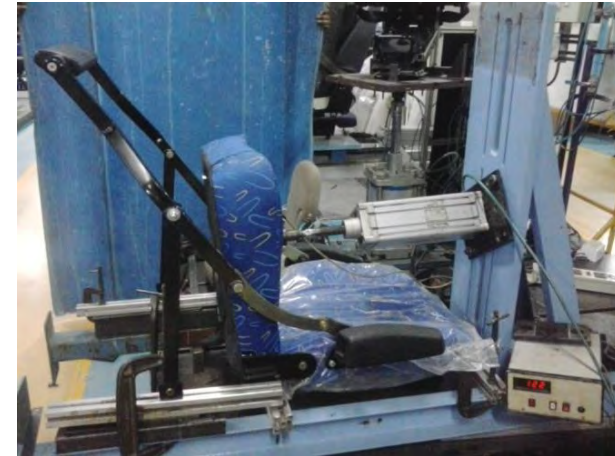

Vertical strength test for co- driver

# Vibration durability testing

Multi-Axis Simulation Table (MAST)



# Durability / performance testing capabilities



Lateral load test



Armrest drop test



Armrest endurance test



Seat base frame strength test



Robotic Ingress Egress test



Reclining endurance test



# Prototype capabilities

CNC foam carving



Upholstery development



Modular locating table with in-house manual & robotic welding

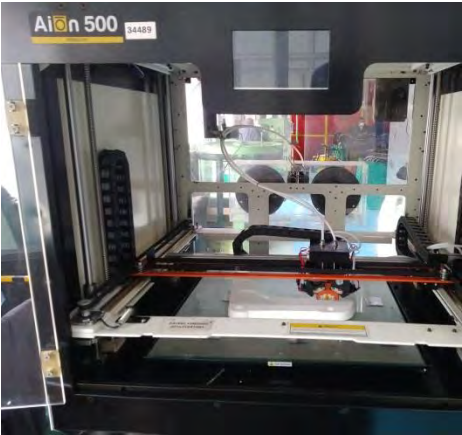

Rapid prototyping

# Bus Passenger seats



# Premium Seats for coaches

Magnum



Futura



Crystal



Utthara



Standard features



Optional features



Mega magnum 3PSB



New deluxe seat



# Futura deluxe seat with cheek support



## Features:

- Reclining backrest with integrated cheek support
- Retractable armrest
- Plastic back cover & side cover
- Plastic leg cover
- Grab handle
- Coat hanger
- Plastic magazine pouch
- 3 point strap type bottle holder
- Fixed footrest with plastic pads
- Fabric / vinyl upholstery
- Dual port USB charger (optional)
- 2P lap belt (optional)
- Calf-support – Mechanical / Gas assisted mechanism (optional)

### Standard features



### Optional features



# Crystal deluxe seat with soft-back



## Features:

- Reclining backrest
- Retractable armrest
- Plastic back cover with soft back on top
- Plastic side cover & leg cover
- Grab handle & coat hanger
- Plastic magazine pouch
- 3 point strap type bottle holder
- 3 position adjustable footrest with plastic pads
- Fabric / vinyl upholstery
- Dual port USB charger (optional)
- 2P lap belt (optional)
- Calf-support – Mechanical / Gas assisted mechanism (optional)

### Standard features



### Optional features



# Mega magnum seat with 3PSB



Standard features



Optional features



## Features:

- Reclining backrest
- Retractable armrest
- Plastic back cover & side cover
- Twin grab handle
- Coat hanger
- Knitted magazine pouch
- 3 point strap type bottle holder
- Fixed footrest with plastic pads
- Dual sensitive 3P seat belt for enhanced safety
- Fabric / vinyl upholstery
- Dual port USB charger (optional)
- Calf-support – Mechanical / Gas assisted (optional)
- Gangway LED light (optional)

# Executive (910) deluxe bus seat



## Features:

- Reclining backrest
- Retractable armrest
- Plastic back cover
- Plastic side cover
- Grab handle & coat hanger
- Plastic magazine pouch
- 3 point strap type bottle holder
- Fabric / vinyl upholstery
- Dual port USB charger (optional)
- Base model : 2P lap belt version
- 3P seat belt version (Optional)

## Optional features



## Standard features



# New deluxe seat



Standard features



Optional features



## Features:

- Reclining backrest with integrated cheek support
- Retractable armrest
- Plastic back cover & side cover
- Plastic leg cover
- Grab handle with coat hook
- Plastic magazine pouch
- Plastic kick plate
- Plastic bottle holder
- Fabric / vinyl upholstery
- 2P lap belt (optional)
- Mobile holder (Optional)
- Snack Tray(Optional)
- Calf support Mechanical / Gas assisted
- Footrest (2-Point / 3Point)
- Rear USB + Type C Charger (Optional)
- Branding on the back cover
- Ambient Light(Optional)



## Injection Moulded seat



Standard features:



## Features:

- Plastic grab handle
- Light weight seats
- Foam pads
- Upholstery at seating area
- Armrest (Optional)
- Lap belt (Optional)
- Stanchion holder (optional)

Optional features:



## Blow Shell seat



# Details of features

Dual port USB Charger



Fully covered armrest



LED Lamp for gangway



3 point seat belt



Gas spring assisted calf support



Cheek support



Anti Viral fabric

# Driver seats

Pneumatic  
suspended seat



Static seat



Static seat



Mechanical suspended seat



Mech. Suspended seat  
Domestic



Static seat



## Design Registrations and Patent filings

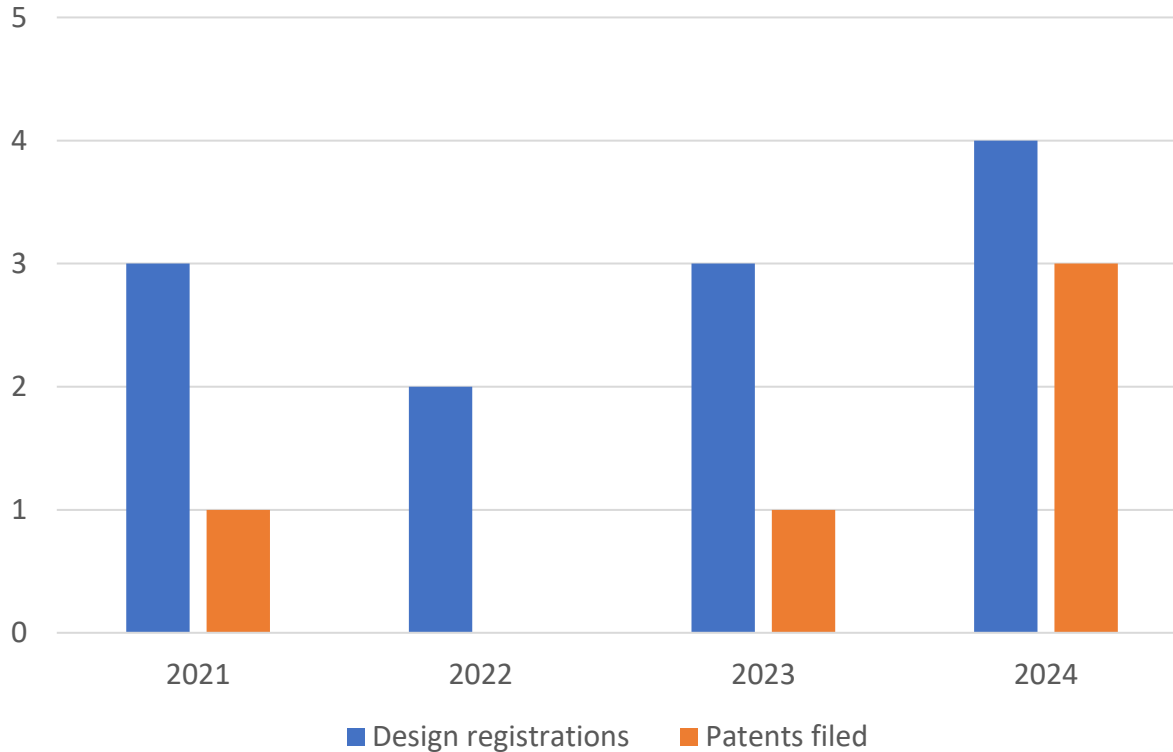

### Seating Division

Holding Patents : 7  
Design registrations: 36





# Thank You

## Corporate Office

**Address:** Village Nawada Fatehpur,  
P.O. Sikanderpur Badda, Manesar,  
Gurgaon – 122004, India.

**Website:** [www.unominda.com](http://www.unominda.com)

**Email ID:** [sk sreeram@unominda.com](mailto:sk sreeram@unominda.com)

Follow us on social media. Links below

